

REACT

QUALITY FIRST

T400 WHEEL LOADER - 180HP



SPEC SHEET

SPECIAL FEATURES

- 4 Ton Capacity
- 180 HP Cummins 6BTA5.9- C180-11
- Genuine Cummins 2000 hr/2yr Warranty
- New Engine Inspection by Cummins Before Delivery
- Extra Large Aluminium Radiator
- Long Life Coolant
- ROPS / FOPS
- YD13 ZF Technology Powershift Transmission
- 4 Fwd / 3 Rev Gears with Safety Lock Out
- 38 km/h Road Speed
- Gear Kick Down Function
- 2.5m³ General Purpose Bucket
- Heavy Duty Pallet Forks
- Heavy Duty Hay Forks
- 12 Stud Axles
- Steering Priority Valve
- Hydraulic Pilot Control
- Auto Forward Reverse
- Hydraulic Quick Release Hitch with Safety Lock Out
- 3500 mm Dumping Height
- Float Function
- Auto Level
- 3rd Function Hydraulics
- Hydraulic Hose Protection
- Auto Greasing
- Luxurious Extra Large Cab
- Reverse Camera / Reverse Alarm
- FM Radio, Fire Extinguisher, Drink Holder & Glass Breaker
- Battery Isolation Switch
- Adjustable Steering Column
- Sound Proofing, Cab Fan & Sun Visor
- Electric Park Brake
- UV Protected Windows
- Australian Standards Air Conditioning
- LED Light Bars Front & Rear
- LED Lights, Blinkers, Hazards & Mirrors
- High Lift Engine Bonnet
- Brilliant Access to Filters, AC & Engine Components
- Rear Access Door to Radiator

Available Extras:

- Numerous Attachments
- Soft Ride
- Rear Rippers
- On Road Package
- UHF
- Registration

*Finance Available



JACOB
0427 180 673
JACOB@TOUGHINDUSTRIAL.COM.AU

AARON
0456 676 700
AARON@TOUGHINDUSTRIAL.COM.AU

KAHIL
0400 459 097
KAHIL@TOUGHINDUSTRIAL.COM.AU



13 NEWCASTLE CRESCENT, CAVAN, SA. 5094

REACT

QUALITY FIRST



T400 WHEEL LOADER - 180HP

SPEC SHEET

TECHNICAL SPECIFICATIONS - 4 TON CAPACITY

Performance

Rated Load	4,000 kg
Overall Weight	12,000 kg
Bucket Capacity	2.5 m ³
Underbelly Clearance	460 mm
Max. Dump Height	3,500 mm
Max. Dump Reach	1,660 mm
Overall Dimension	Length 8,150 mm Width 2,450 mm Height 3,450 mm

Engine

Model	Cummins 6BTA5.9- C180-11
Type	Turbocharged / Water Cooled
Rated RPM	2,200 rpm
Rated Power	180 hp / 135 kw
Max. Torque	

Service Refill Capacities

Fuel	140 ltr
Hydraulic Oil	100 ltr
Engine Oil	15 ltr
Transmission	35 ltr
Axles x 2	16 ltr

Transmission

YD13

Type	YD13 ZF Technology Powershift Trans.
Gears	4 Forward, 3 Reverse
Working Pressure	1.6 mpa
Max. Speed	38 km/h

Drive Axle

Main Reducing Spiral Decelerating Mode	Planetary reduction
Wheel Base	2,970 mm
Inner Wheel Tread	1,250 mm
Ground Clearance	460 mm

Hydraulic System

System Working Pressure	18.5 mpa
Boom Lifting Time (max load)	5.5 Sec
Lowering Time (empty)	3.5 Sec
Dumping Time (empty)	1.5 Sec
Auto Bucket Level	Yes
3rd Function Oil Flow	180 - 200 lpm

Tyres

Tube Standard (tubeless optional)	20.5-25 20 pr
Front Tyre Pressure	50 psi
Rear Tyre Pressure	42 psi

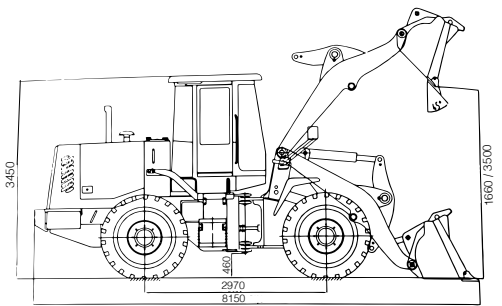

*All diagram measurements in millimeters (mm)

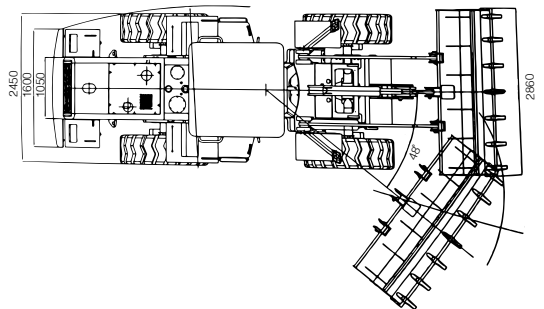

Prices exclude GST

WWW.REACTINTERNATIONAL.COM.AU