

REACT

QUALITY FIRST

G300 WHEEL LOADER - 130HP

SPEC SHEET



SPECIAL FEATURES

- 3 ton Lifting Capacity
- 130HP Cummins Engine
- 6BT5.9-C130-II
- Jinite 315 Transmission
- Extensive Pre-Delivery Service
- Cummins 2 Year Warranty
- Engine Inspected by Cummins
- Long Life Anti Corrosion Coolant
- 35 km/h Road Speed
- 17.5-25 16Ply Tires
- 1.6m³ General Purpose Bucket
- Pallet Forks (Standard)
- Hay Forks (Standard)
- Steering Priority Valve
- Hydraulic Pilot Control
- Auto Forward Reverse
- Hydraulic Quick Release Hitch
- Float Function
- 3rd Function Hydraulics
- Reverse Camera and Alarm
- Adjustable Steering Column
- Sound Proofing, Cab Fan & Sun Visor
- Hand Park Brake
- UV Protected Windows
- Australian Standard Air Conditioning
- LED Lights, Blinkers, Hazards
- Adjustable Mirrors

Available Extras:

- Numerous Attachments
- Soft Ride
- On Road Package
- Registration

* Finance Available

JACOB
0427 180 673
JACOB@TOUGHINDUSTRIAL.COM.AU

AARON
0456 676 700
AARON@TOUGHINDUSTRIAL.COM.AU

KAHIL
0400 459 097
KAHIL@TOUGHINDUSTRIAL.COM.AU



13 NEWCASTLE CRESCENT, CAVAN, SA. 5094

REACT

QUALITY FIRST



G300 WHEEL LOADER - 130HP

SPEC SHEET

TECHNICAL SPECIFICATIONS - 3 TON CAPACITY

Performance

Rated Load	3,000 kg
Overall Weight	9,000 kg
Bucket Capacity	1.6 m ³
Underbelly Clearance	400 mm
Max. Dump Height	3,200 mm
Max. Dump Reach	1,600 mm
Overall Dimension	Length 7,100 mm Width 2,120 mm Height 3,170 mm

Engine

Model	Cummins 6BT5.9-C130
Type	Turbocharged / Water Cooled
Rated RPM	2,200 rpm
Rated Power	130 hp / 97 kw
Max. Torque	670 nm

Service Refill Capacities

Fuel	100 ltr
Hydraulic Oil	80 ltr
Engine Oil	15 ltr
Transmission	35 ltr
Axles x 2	16 ltr

Transmission

JINLITE 315

Type	Jinlite 315 Transmission
Gears	4 Speed / High Low
Working Pressure	1.6 mpa
Max. Speed	35 km/h

Drive Axle

Decelerating Mode	Planetary Reduction
Wheel Base	2,700 mm
Inner Wheel Tread	1,200 mm
Axel Clearance	430 mm

Hydraulic System

System Working Pressure	18.5 mpa
Boom Lifting Time (max load)	5.5 Sec
Lowering Time (empty)	3.5 Sec
Dumping Time (empty)	1.5 Sec
3rd Function Oil Flow	180 - 200 lpm

Tyres

Tube Standard (tubeless optional)	19.5-24 pr
Front Tyre Pressure	45 psi
Rear Tyre Pressure	40 psi

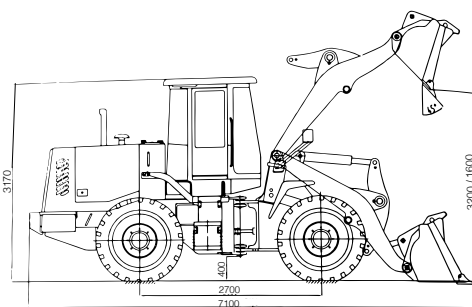

*All diagram measurements in millimeters (mm)

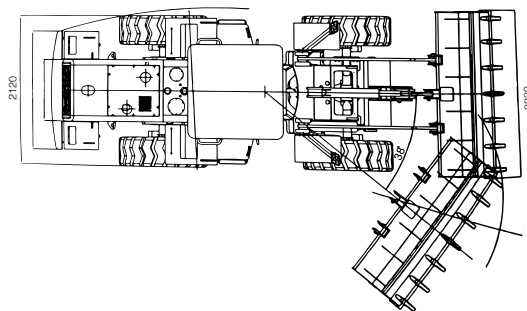

Prices exclude GST

WWW.REACTINTERNATIONAL.COM.AU