

# REACT

QUALITY FIRST

## T600 WHEEL LOADER - 240HP



SPEC SHEET

### SPECIAL FEATURES

- 6 Ton Lifting Capacity
- 240 HP Cummins 6CTA8.3-C240
- Genuine Cummins 2000 hr/2yr Warranty
- New Engine Inspection by Cummins
- Extra-Large Aluminium Radiator
- Long Life Anti Corrosion Coolant
- 4 speed ZF WG 200 Powershift Transmission
- 4 Fwd / 3 Rev Gears with Safety Lock Out
- 38 km/h Road Speed
- Gear Kick Down Function
- 3.5m<sup>3</sup> General Purpose Bucket
- Heavy Duty Pallet Forks
- Heavy Duty Hay Forks
- 12 Stud Axles
- Steering Priority Valve
- Hydraulic Pilot Control
- Hydraulic Quick Release Hitch
- Quick Hitch Safety Lock Out
- 3,700 mm Dumping Height
- Float Function
- Auto Level
- 3rd Function Hydraulics
- Hydraulic Hose Protection
- Lincoln SKF Auto Greaser
- Luxurious Extra Large Cab
- Reverse Camera / Reverse Alarm
- FM Radio, Fire Extinguisher, Drink Holder & Glass Breaker
- Battery Isolation Switch
- Adjustable Steering Column
- Sound Proofing, Cab Fan & Sun Visor
- Electric Park Brake
- UV Protected Windows
- Australian Standards Air Conditioning
- LED Light Bars Front & Rear
- LED Lights, Blinkers, Hazards & Mirrors
- Excellent Filter Access & Engine Components

### Available Extras:

- Numerous Attachments
- Soft Ride
- Rear Rippers
- On Road Package
- UHF
- Registration

Finance Available

JACOB  
0427 180 673  
JACOB@TOUGHINDUSTRIAL.COM.AU

AARON  
0456 676 700  
AARON@TOUGHINDUSTRIAL.COM.AU

KAHIL  
0400 459 097  
KAHIL@TOUGHINDUSTRIAL.COM.AU



WWW.REACTINTERNATIONAL.COM.AU

# REACT

QUALITY FIRST



## WG200 WHEEL LOADER - 240HP

SPEC SHEET

### TECHNICAL SPECIFICATIONS - 6 TON CAPACITY

#### Performance

Rated Load	6,000 kg
Overall Weight	20,000 kg
Bucket Capacity	3.5 m <sup>3</sup>
Underbelly Clearance	540 mm
Max. Dump Height	3,700 mm
Max. Dump Reach	1,600 mm
Overall Dimension	Length 8,900 mm Width 3,000 mm Height 3,510 mm

#### Engine

Model	Cummins 6CTA8.3-C240
Type	Turbocharged / Water Cooled
Rated RPM	2,200 rpm
Rated Power	179 kw
Max. Torque	

#### Service Refill Capacities

Fuel	300 ltr
Hydraulic Oil	260 ltr
Engine Oil	19 ltr
Transmission	35 ltr

#### Transmission

#### WG200

Type	Powershift Transmission
Gears	4 Forward, 3 Reverse
Working Pressure	16 mpa
Max. Speed	38 km/h

#### Drive Axle

Decelerating Mode	Planetary reduction
Wheel Base	3,450 mm
Inner Wheel Tread	1,900 mm
Axle Clearance	550 mm

#### Hydraulic System

System Working Pressure	18 mpa
Boom Lifting Time (max load)	5.5 Sec
Lowering Time (empty)	4.5 Sec
Dumping Time (empty)	4.5 Sec
Working Pressure	18 mpa
3rd Function Oil Flow	180 - 200 lpm

#### Tyres

Tube Standard (tubeless optional)	26.5-25 (20ply)
Front Tyre Pressure	60 psi
Rear Tyre Pressure	55 psi

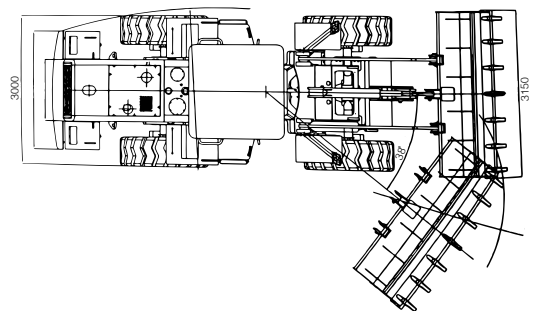
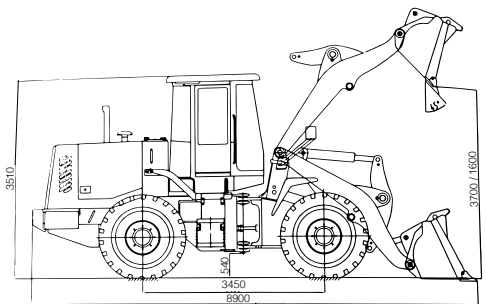

Prices exclude GST

13 NEWCASTLE CRESCENT, CAVAN, SA. 5094