

REACT

QUALITY FIRST

T500 WHEEL LOADER - 220HP

SPEC SHEET



SPECIAL FEATURES

- 5 Ton Capacity
 - 215 HP Cummins 6CTA8.3-C215
 - Genuine Cummins 2000 hr/2yr Warranty
 - New Engine Inspection by Cummins Before Delivery
 - Extra Large Aluminium Radiator
 - Long Life Coolant
 - 38 km/h Road Speed
 - ROPS / FOPS
 - WG180 ZF Technology Transmission
 - 4 Fwd / 3 Rev Gears with Safety Lock Out
 - Gear Kick Down Function
 - 3m³ General Purpose Bucket
 - Heavy Duty Pallet Forks
 - Heavy Duty Hay Forks
 - 12 Stud Axles
 - Hydraulic Pilot Control
 - Hydraulic Quick Release Hitch with Safety Lock Out
 - Steering Priority Valve
 - 3,600 mm Dumping Height
 - Float Function
 - Auto Level
 - 3rd Function Hydraulics
 - Hydraulic Hose Protection
 - Auto Greasing
 - Luxurious Extra Large Cab
 - Reverse Camera / Reverse Alarm
 - FM Radio, Fire Extinguisher, Drink Holder & Glass Breaker
 - Adjustable Steering Column
 - Electric Park Brake
 - Battery Isolation Switch
 - UV Protected Windows
 - Sound Proofing, Cab Fan & Sun Visor
 - Australian Standards Air Conditioning
 - LED Light Bars Front & Rear
 - LED Lights, Blinkers, Hazards & Mirrors
 - High Lift Engine Bonnet
 - Brilliant Access to Filters, AC & Engine Components
 - Rear Access Door To Radiator
- Available Extras:**
- Numerous Attachments
 - Soft Ride
 - Rear Rippers
 - On Road Package
 - UHF
 - Registration
- Finance Available



JACOB
0427 180 673
JACOB@TOUGHINDUSTRIAL.COM.AU

AARON
0456 676 700
AARON@TOUGHINDUSTRIAL.COM.AU

KAHIL
0400 459 097
KAHIL@TOUGHINDUSTRIAL.COM.AU

13 NEWCASTLE CRESCENT, CAVAN, SA. 5094

REACT

QUALITY FIRST



T500 WHEEL LOADER - 220HP

SPEC SHEET

TECHNICAL SPECIFICATIONS - 5 TON CAPACITY

Performance

Rated Load	5,000 kg
Overall Weight	17,000 kg
Bucket Capacity	3 m ³
Underbelly Clearance	550 mm
Max. Dump Height	3,600 mm
Max. Dump Reach	1,200 mm
Overall Dimension	Length 8,300 mm Width 3,050 mm Height 3,500 mm

Engine

Model	6CTA8.3-C215
Type	Cummins
Rated RPM	2,200 rpm
Rated Power	160 kw
Max. Torque	950 nm

Service Refill Capacities

Fuel	250 ltr
Hydraulic Oil	170 ltr
Engine Oil	19 ltr
Transmission	35 ltr
Axles x 2	25 ltr

Transmission

WG180

Type	WG180 ZF Technology Transmission
Gears	4 Forward, 3 Reverse
Working Pressure	16 mpa
Max. Speed	38 km/h

Drive Axle

Main Reducing Spiral Decelerating Mode	
Wheel Base	3,200 mm
Inner Wheel Tread	1,800 mm
Ground Clearance	550 mm

Hydraulic System

System Working Pressure	18 mpa
Boom Lifting Time (max load)	5.5 Sec
Lowering Time (empty)	4.5 Sec
Dumping Time (empty)	4.5 Sec
3rd Function Oil Flow	180 - 200 lpm
Auto Bucket Level	Yes

Tyres

Tube Standard (tubeless optional)	23.5/25 pr
Front Tyre Pressure	55 psi
Rear Tyre Pressure	50 psi

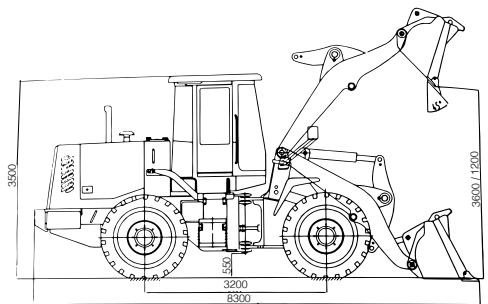

*All diagram measurements in millimeters (mm)

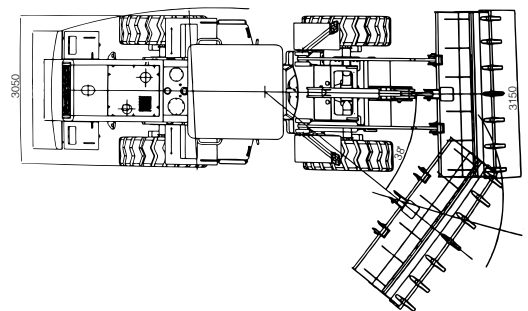

Prices exclude GST