

REACT

QUALITY FIRST

G200 WHEEL LOADER - 100HP



SPEC SHEET

SPECIAL FEATURES

- 2 Ton Lifting Capacity
- 100HP Cummins Engine 4BTA3.9-C100-II
- Extensive Pre-Delivery Service
- Genuine Cummins 2 Year Warranty
- Engine Inspected by Cummins
- Long Life Coolant
- Jinlite 280 Transmission
- 35 km/h Road Speed
- 1.2m³ General Purpose Bucket
- Pallet Forks (Standard)
- Hay Forks (Standard)
- Steering Priority Valve
- Hydraulic Pilot Control
- Tyres: 16ply 16/70-24
- Deluxe Cab
- Auto Forward Reverse
- Hydraulic Quick Release Hitch
- 2800 mm Dumping Height
- Float Function
- 3rd Function Hydraulics
- Reverse Camera / Alarm
- FM Radio, Fire Extinguisher, Drink Holder & Glass Breaker
- Adjustable Steering Column
- Sound Proofing, Cab Fan & Sun Visor
- Hand Park Brake
- UV Protected Windows
- Australian Standard Air Conditioning
- LED Lights, Blinkers, Hazards
- Adjustable Mirrors

Available Extras:

- Numerous Attachments
- Soft Ride
- Registration
- UHF
- Complete on Road Package

* Finance Available



JACOB
0427 180 673
JACOB@TOUGHINDUSTRIAL.COM.AU

AARON
0456 676 700
AARON@TOUGHINDUSTRIAL.COM.AU

KAHIL
0400 459 097
KAHIL@TOUGHINDUSTRIAL.COM.AU



13 NEWCASTLE CRESCENT, CAVAN, SA. 5094

REACT

QUALITY FIRST



G200 WHEEL LOADER - 100HP

SPEC SHEET

TECHNICAL SPECIFICATIONS - 2 TON CAPACITY

Performance

Rated Load	2,000 kg
Overall Weight	5 ton
Bucket Capacity	1.2 m ³
Underbelly Clearance	380 mm
Max. Dump Height	2,800 mm
Max. Dump Reach	850 mm
Overall Dimension	Length 6,100 mm Width 2,050 mm Height 2,990 mm

Engine

Model	Cummins 4BTA3.9-C100-II
Type	Water Cooled
Rated RPM	2,400 rpm
Rated Power	75 kw
Max. Torque	260 nm

Service Refill Capacities

Fuel	100 ltr
Hydraulic Oil	80 ltr
Engine Oil	15 ltr
Transmission	25 ltr

Transmission

JINLITE 280

Type	Jinlite 280 Transmission
Gears	4 gears (Hi/L0)
Working Pressure	
Max. Speed	35 km/h

Drive Axle

Main Reducing Spiral Decelerating Mode	With Differential Wheel-reducer Axle
Wheel Base	2,500 mm
Inner Wheel Tread	1,200 mm
Ground Clearance	380 mm

Hydraulic System

System Working Pressure	16 mpa
Boom Lifting Time (max load)	5 Sec
Lowering Time (empty)	4 Sec
Dumping Time (empty)	2.3 Sec
Working Pressure	16 mpa
3rd Function Oil Flow	120 lpm

Tyres

Tube Standard (tubeless optional)	16/70-24 ply
Front Tyre Pressure	45 psi
Rear Tyre Pressure	45 psi

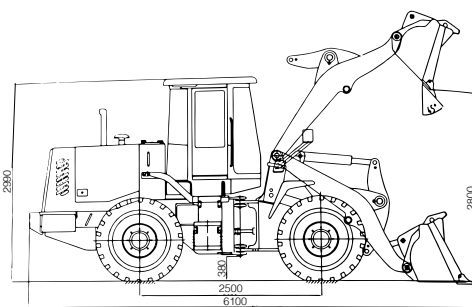

*All diagram measurements in millimeters (mm)

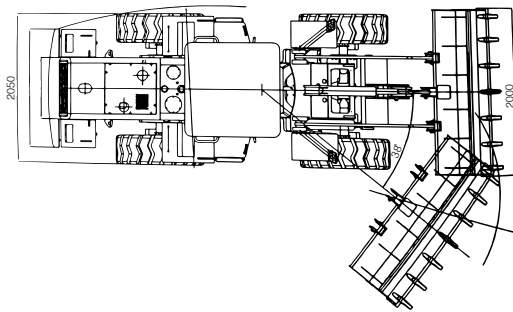

Prices exclude GST

WWW.REACTINTERNATIONAL.COM.AU